	WARNING	Disconnect from power source to prevent electrical shock before installing or servicing. Check power supply voltage and frequency.
	AVERTISSEMENT	Déconnecter l'alimentation avant toute opération d'installation ou de maintenance, afin d'éviter les décharges électriques. Contrôler la tension et la fréquence d'alimentation.
	WARNUNG	Schalten Sie den Strom während der Installation oder bei Wartungsarbeiten ab um einen elektrischen Schlag zu vermeiden. Prüfen Sie die Spannung und Frequenz der Stromquelle.
	AVVERTENZA	Scollegare dall'alimentazione prima dell'installazione e della messa in servizio. Controllare la tensione di alimentazione e la frequenza.
	ATENÇÃO	Desligar a alimentação antes de realizar qualquer intervenção. Verificar a tensão e frequência da alimentação.
	ADVERTENCIA	Durante el proceso de instalación o mantenimiento desconectar la tensión de alimentación para evitar descargas eléctricas. Comprobar tensión y frecuencia de alimentación.

TEMPERATURE RANGE, TEMPÉRATURE D'UTILISATION, TEMPERATURBEREICH -30°C .. +60°C
 INTERVALLO TEMPERATURE, GAMA DE TEMPERATURA, RANGO DE TEMPERATURA -22 F .. +140 F

Installation
Installation
Installation
Installazione
Instalação
Instalación

Surface Mount
Montage en saillie
Oberflächenmontage
Superficie Montaggio
Montagem De Superficie
Montaje Superficie

(UL TYPE 4, 4X, 13)

Mounting screws not provided
Vis de montage non-fournis.
Befestigungsschrauben sind im
Lieferumfang nicht enthalten.
Viti di montaggio non incluse.
Parafusos para montagem não
são fornecidos.
No se incluyen los tornillos de
montaje.

Seal Washers
Rondelles d'étanchéité
Dichtungsscheiben
Rondelle di tenuta
Anilhas de vedação
Arandelas de cierre

(AG1 - AG4)

Gasket not provided
Joint Plat non-fournis.
Dichtung ist im
Lieferumfang nicht enthalten.
Guarnizione non incluse.
Juntas não incluídas.
No se incluyen los Junta.

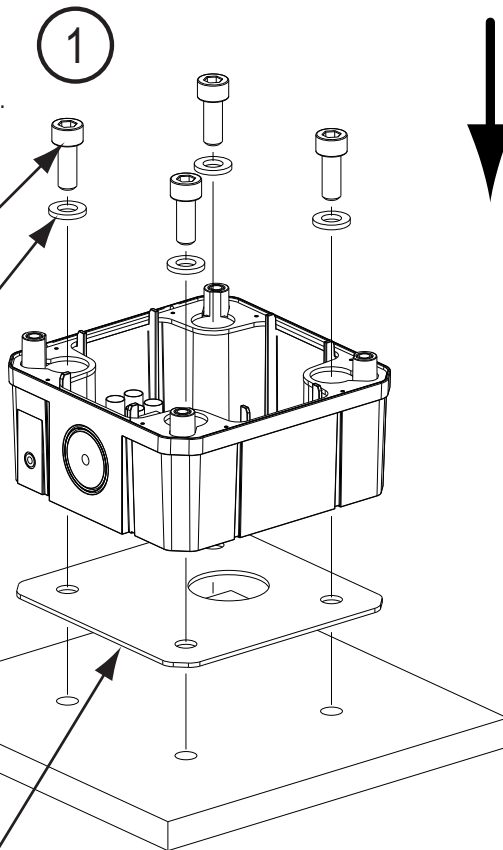

2

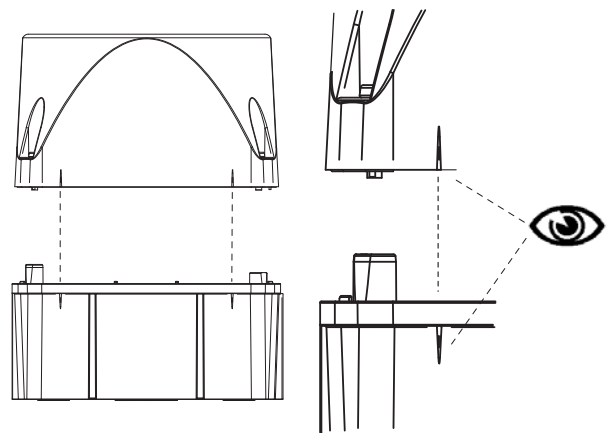

3

4x

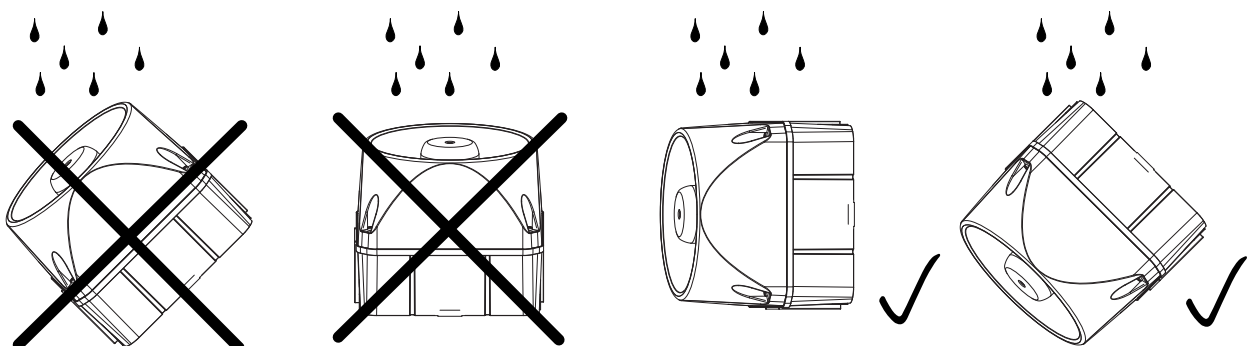
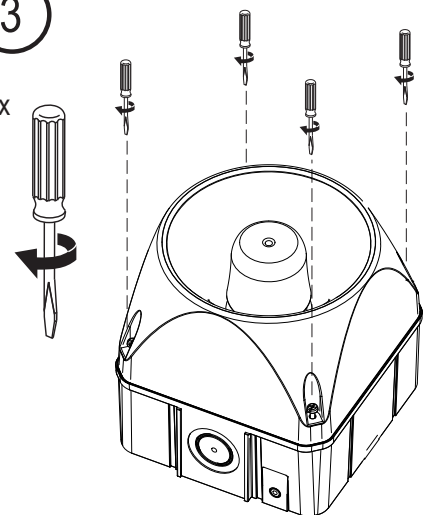



WARNING

AVERTISSEMENT

WARNUNG

AVVERTENZA

ATENÇÃO

ADVERTENCIA

Bonding between conduit connections is not automatic and must be provided as a part of the installation.

La connexion des masses n'est pas réalisée automatiquement par les raccordements des gaines et doit être prévue séparément lors de l'installation.

Die Verbindung zwischen Leitungsanschlüssen wird nicht automatisch hergestellt und muss bei der Installation erfolgen.

il collegamento a massa tra i connettori delle guaine non è automatico e deve essere previsto nell'ambito dell'installazione.

A ligação entre as conexões de conduíte não é automática e deve ser fornecida como parte da instalação.

El enlace entre las conexiones del conducto no es automático y debe hacerse como parte de la instalación.

Electrical Connection
Raccordement Electrique
Elektrischer Anschluß
Collegamento Elettrico
Ligações Eléctricas
Conexiones Eléctricas

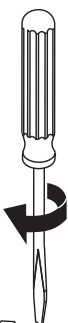

0.56 N•m
(UL: 5 lb-in)

7 mm
(0.28 in)

Max. 2.5 mm²
(Max. #14 AWG)

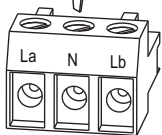

La N Lb

L	N			
L	N	L	+	ADS-T
	N	L		ADS-P

Bonding
Liaison
Verbindung
Collegamento
Ligação
Conexión

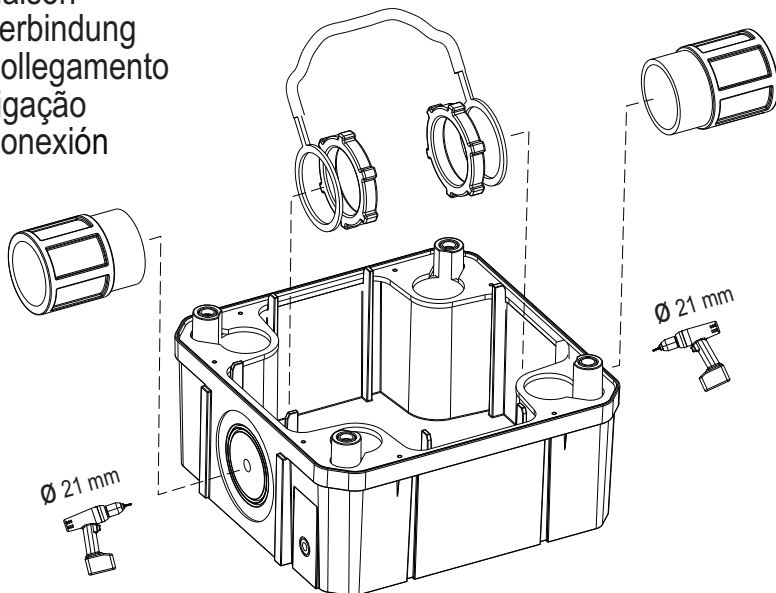

Stage control
Sélection de la table de sons
Auswahl der Tontabelle
Selezione stage
Controle de estado
Cableado de control

S2	0	S3	
no connection			STAGE 1
			STAGE 2
			STAGE 3

Not for ASS-P and ADS-P
Sauf pour ASS-P et ADS-P
Gilt nicht für ASS-P und ADS-P
Non valido per ASS-P e ADS-P
Não aplicável a ASS-P e ADS-P
No para ASS-P y ADS-P

Jumper, Cavalier, Brücke, Ponticello, Ponte, Puente

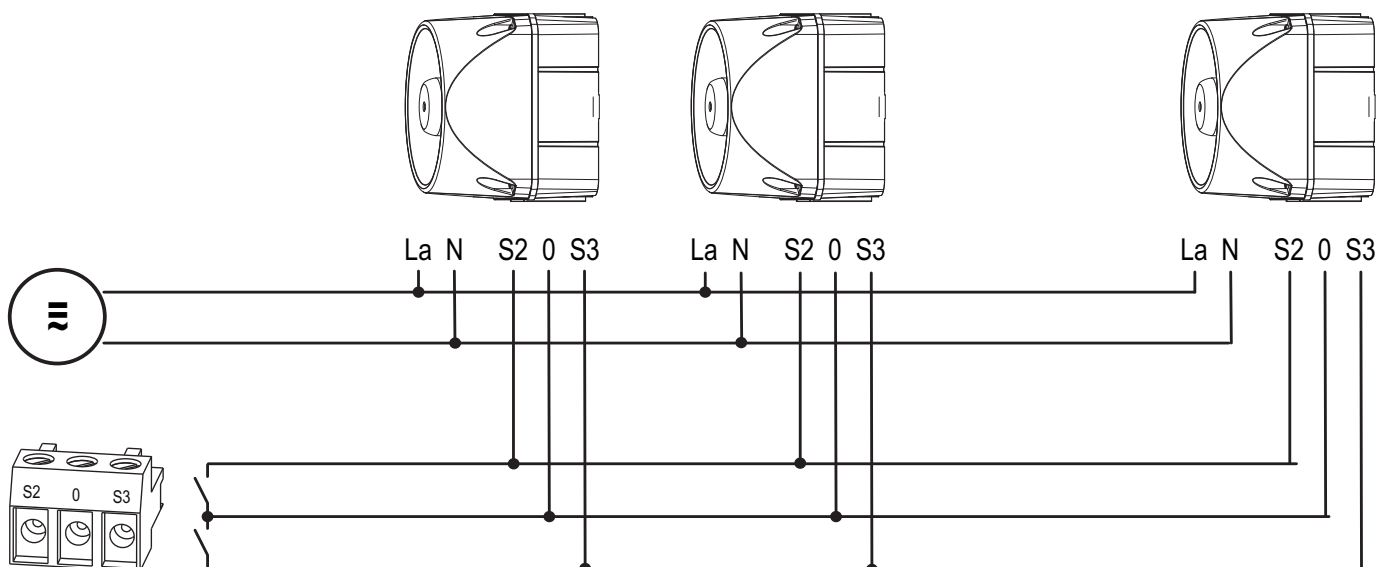

Cable gland
 Presse-étoupe
 Kabelverschraubung
 Pressacavo
 Bucim
 Entrada de cable

0,5 - 4,0 mm²
 #12 - #18 AWG

Ø 5 - 10mm
 (0.20" - 0.40")

Type AKV
 Ø 7-14 mm
 (0.28" - 0.55")

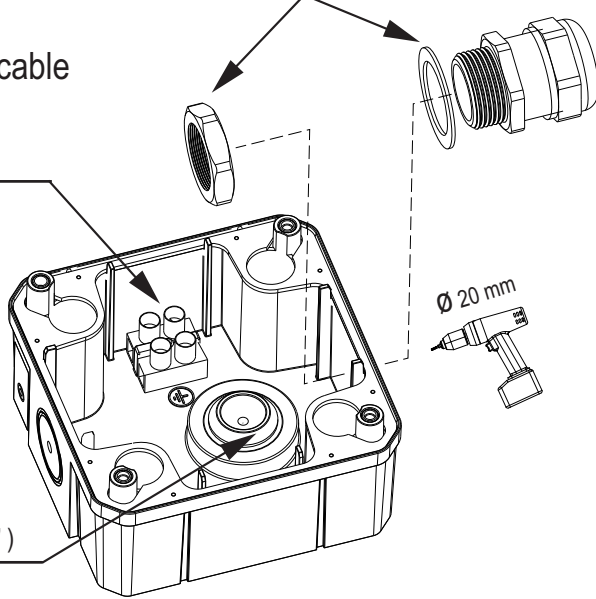

Metal Bracket Mount
 Montage de l'équerre métallique
 Metall Winkelmontage
 Staffa di montaggio in metallo
 Montagem do suporte metálico
 Escuadra metálica de montaje

Type AB1-AB4

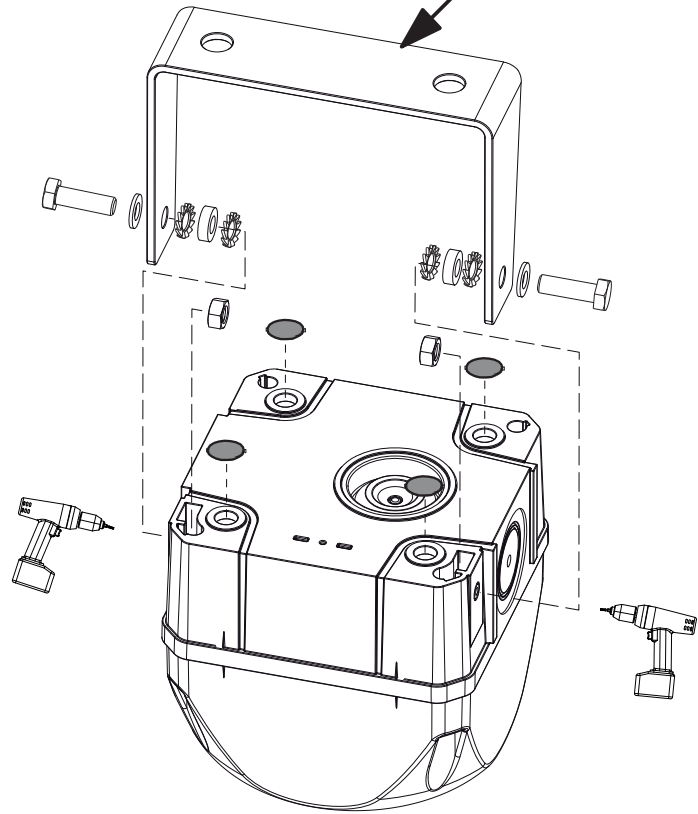

Volume
 Volume
 Lautstärke
 Volume
 Volume
 Volumen

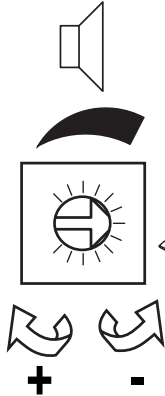

Not for ASX, ADX, ACX
 Sauf pour ASX, ADX, ACX
 Gilt nicht für ASX, ADX, ACX
 Non valido per ASX, ADX, ACX
 Não aplicável a ASX, ADX, ACX
 No para ASX, ADX, ACX

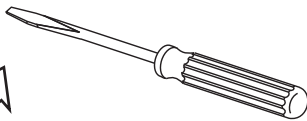

Mounting Kit AMK
 Kit d'assemblage
 Montagesatz AMK
 Kit di montaggio AMK
 Kit de montagem AMK
 Kit de montaje AMK

Type AMK

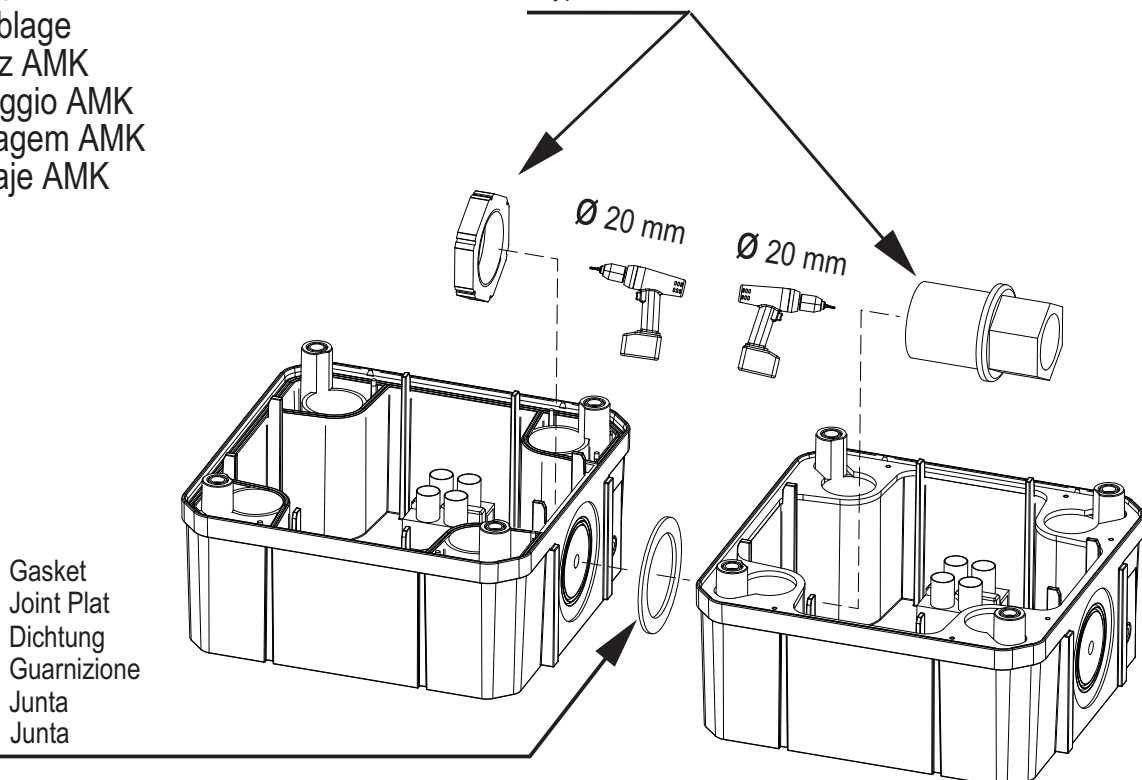

Gasket
 Joint Plat
 Dichtung
 Guarnizione
 Junta
 Junta

Drilling pattern, Schéma de perçage, Bohrbild, Dima di foratura, Padrão de perfuração, Plantilla patrón

Surface Mount
Montage en saillie
Oberflächenmontage
Superficie Montaggio
Montagem de Superfície
Montaje Superficie

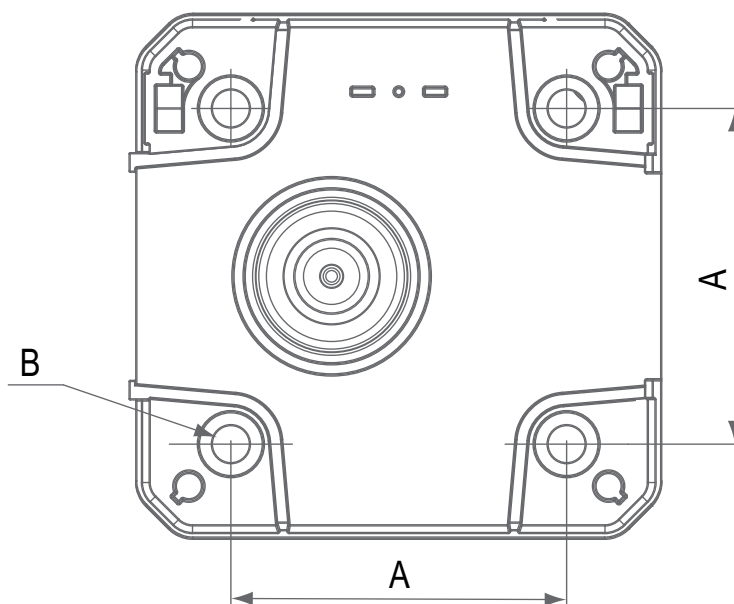

Type	A	B
ASS-T, ASS-P, ADS-T, ADS-P	60 mm (2,36")	6,5 mm (0,26")
ASM, ADM, ACM	91 mm (3,58")	6,5 mm (0,26")
ASL, ADL, ACL	124 mm (4,88")	6,5 mm (0,26")
ASX, ADX, ACX	167 mm (6,57")	6,5 mm (0,26")

Mounting option with metal bracket
Montage avec équerre métallique
Montage mit Metallwinkel
Fissaggio con staffa metallica
Montagem com suporte metálico
Montaje con escuadra metálica

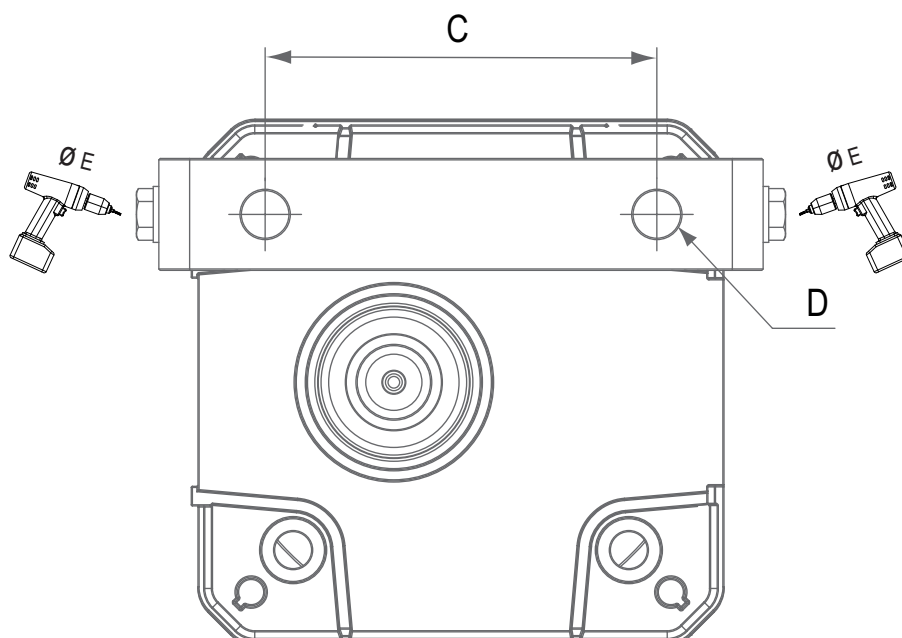

Type	C	D	E
AB1	70 mm (2,76")	8,0 mm (0,31")	5,5mm (0,22")
AB2	95 mm (3,74")	8,5 mm (0,33")	6,5 mm (0,26")
AB3	112 mm (4,41")	8,5 mm (0,33")	6,5 mm (0,26")
AB4	140 mm (5,51")	8,5 mm (0,33")	6,5 mm (0,26")