

Ex Sounder

Typ dHE



Operating instructions



Note

Please read this manual carefully before installing the sounder.

Application

The Ex Sounder dHE is a signalling device that generates various signalling tones and signalling tone sequences and emits them at a high sound pressure level. The user may choose between 31 preset signalling tone groups and one programmable one. Every signalling tone group contains 4 different signalling tones. Wire the control inputs with floating contacts or jumpers in order to choose any one of these 4 signalling tones. The sounder has 8 volume levels. All outer fastening parts are made of non-corrosive materials. The stable, all-plastic housing conforms to protection degree IP 66, which means the sounder can be installed both indoors and outdoors. Explosion category II 2 G Ex demb IIC T6 allows the sounder to be operated in hazardous areas of zones 1 and 2.

Setting the volume and the signalling tone groups prior to mounting the sounder

The sounder ships with the following setting:

Sound pressure:	maximum
Signalling tone group:	Group0: continuous tone 1000 Hz; sweeping tone 1200 Hz / 500 Hz; intermittent tone 1000 Hz
Selected signalling tone:	continuous tone 1000 Hz

If you want other signalling tones and volume levels, please follow the instructions below. To set the sound pressure level and the signalling tone groups, open the sounder housing. To do this you have to place the sounder on a level surface, the loudspeaker opening facing upwards. Loosen the 8 housing screws and lift the upper part of the housing slightly. Detach the connecting cable running from the loudspeaker to the circuit board at the circuit board and put the loudspeaker part aside. In the bottom part of the housing, on the circuit board, you will find the controls and an LED that are required to set the signalling tone groups.

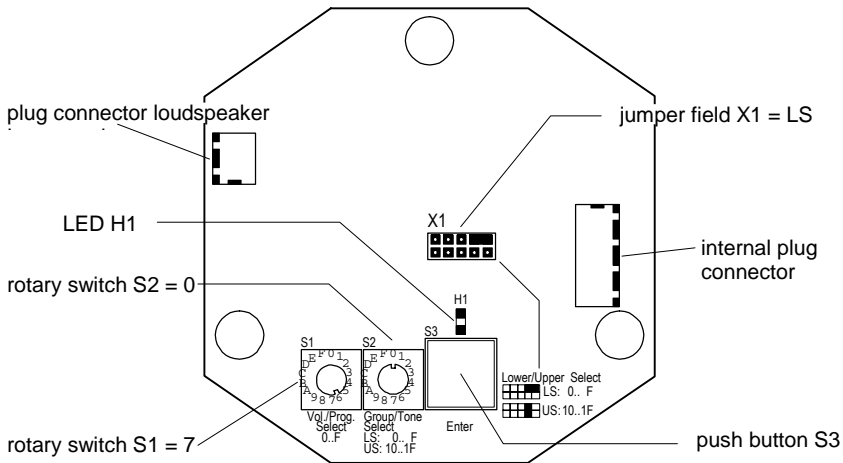

Controls:

Rotary switch S1: **Vol./Prog.
Select
0..F**

Settings:

- 0-7 Sound pressure level setting for normal operation. The 0 setting results in normal operation with the lowest possible volume, whereas the 7 setting results in normal operation with the highest possible volume.
- 8-B Programming the signalling tone group GroupF. The device is forced to go mute and LED H1 is switched on.
- C-F Reserved, do not set! The device is forced to go mute.

Note:

Setting the reserved positions C-F may alter the programming of the signalling tone group GroupF.

Rotary switch S2: **Group/Tone
Select
LS: 0..F
US: 10..1F**

Settings:

- 0-F Selecting the signalling group Group0.. GroupF, when the jumper for LS has been set,
- or
- 0-F Selecting the signalling group Group10.. Group1F, when the jumper for US has been set,

Jumper field X1: Lower/Upper Select

LS: 0..F

US: 10..1F

Settings:

Jumper LS: Signalling tone group Group0...GroupF is selected using rotary switch S2.

Jumper US: Signalling tone group Group10...Group1F is selected using rotary switch S2.

Notes:

If a jumper is lacking the setting LS is active.

Set the jumpers in the marked positions LS or US of the jumper field only. Setting the jumpers in any other position might reduce the functionality of the device.

Push button S3 Enter

Key for programming the signalling tone group GroupF.

LED H1

Programming assistance LED

Procedure for setting the sound pressure level

The programming procedure described below must be performed outside of hazardous areas only, because the opened device has to be supplied with voltage during the procedure.

Turn the rotary switch S1 (Vol./Prog. Select 0..F) to a position between 0 and 7. Position 7 represents the maximum sound pressure level. For each of the positions 6 through 0 the sound pressure level is reduced by 3 dB(A).

Procedure for setting a signalling tone group

The active signalling tone group determines the 4 signalling tones that may be selected from the control inputs during operation.

Setting the active signalling tone group

- a.) From the table „Signalling tone groups“, select the group to which the 4 signalling tones belong that you want to select by connecting the control inputs during operation.
- b.) If the selected signalling tone group belongs to one of the groups Group0 to GroupF, place the jumper in jumper field X1 in position LS. Otherwise, place the jumper in position US. Turn the rotary switch S2 (Group/Tone Select LS:0..F US: 10..1F) to the position corresponding to the last character of the line name of the selected signalling tone group. For instance to position A for the selected signalling tone group GroupA or to position 5 for the selected signalling tone group Group15.

For the signalling tone group GroupF, the composition of the 4 signalling tones is freely programmable. Any one of the signalling tones Tone0 to Tone1F from the table “Signalling tone description” may be freely assigned to the settings Stage 0, Stage 1, Stage 2 and Stage 3. This programming procedure is described in greater detail below.

Signalling tone group GroupF programming procedure

Any one of the signalling tones from the table “Signalling tone description” may be freely assigned to the settings Stage 0, Stage 1, Stage 2 and Stage 3 of the signalling tone group GroupF, in order to compose exactly the 4 signalling tones in signalling tone group GroupF that are required for a certain application.

Programming the signalling tone group GroupF

- a.) First, turn the rotary switch S1 (Vol./Prog. Select 0..F) to one of the positions 8, 9, A or B, in order to force the device into the “mute” setting when the mains supply is switched on.
- b.) Turn on the mains supply of the device. The device goes mute and LED H1 is switched on.
- c.) In order to change a particular signalling tone, use the rotary switch S1 (Vol./Prog. Select 0..F) to select the corresponding setting among the Stage 0, Stage 1, Stage 2 or Stage 3 settings of signalling tone group GroupF. Do this by turning the rotary switch S1 to position 8 (Stage 0), 9 (Stage 1), A (Stage 2) or B (Stage 3).
- d.) Select the desired new signalling tone from the table “Signalling tone description”.
- e.) If the selected signalling tone belongs to the tone interval Tone0 to ToneF, place the jumper in jumper field X1 in position LS. Otherwise, place the jumper in position US. Turn the rotary switch S2 (Group/Tone Select LS:0..F US: 10..1F) to the position corresponding to the last character of the line name of the selected signalling tone. For instance to position A for the selected signalling tone ToneA or to position 5 for the selected signalling tone Tone15.
- f.) Press push button S3 (Enter) to trigger the programming procedure. LED H1 will be turned off during programming, and then on again after the programming is completed. Repeat steps c.) to f.) for all the settings of those tones of signalling tone group GroupF that you want to change.
- g.) Turn off the mains supply of the device.
- h.) Turn rotary switch S1 (Vol./Prog. Select 0..F) back to the preferred volume setting between position 0 and 7, place the jumper in jumper field X1 in position LS, and turn rotary switch S2 (Group/Tone Select LS:0..F US: 10..1F) to position F.

Pick up the loudspeaker part of the housing again, connect the loudspeaker cable with the circuit board in the lower part and place the loudspeaker part on top of the lower part. Connect the housing parts with each other using the 8 housing screws. (Torque 3 Nm ± 0.3 Nm)

Setting the volume and the signalling tone groups following sounder mounting

If the signalling tone and sound pressure level settings must be changed after the device has been mounted, the sounder must be dead (no-voltage). **Wait more than 15 minutes before opening the device.**

Loosen the 8 housing screws and lift the upper part of the housing slightly. Detach the connecting cable running from the loudspeaker to the circuit board at the circuit board and put the loudspeaker part aside. Perform the setting as described above.

Warning:

The programming of signalling tone group GroupF must be performed outside of hazardous areas only, because the opened device has to be supplied with voltage during the procedure.

Table: Signalling tone groups

Stage 0..Stage 3 represent the signalling tones selected via the connections of the control inputs.

	Stage 0			Stage 1		Stage 2		Stage 3		1)
	3	4	5	3-----4	5	3	4-----5	3-----4-----5		
Group0	Mute			Tone0		Tone1E		Tone9	Jumper in position LS of jumper field X1	
Group1	Mute			Tone1		ToneB		Tone13		
Group2	Mute			Tone2		Tone1		Tone13		
Group3	Mute			Tone3		Tone4		Tone13		
Group4	Mute			Tone4		Tone5		Tone13		
Group5	Mute			Tone5		Tone8		Tone13		
Group6	Mute			Tone6		Tone1		Tone13		
Group7	Mute			Tone7		Tone12		Tone1		
Group8	Mute			Tone8		Tone5		Tone13		
Group9	Mute			Tone9		Tone1E		Tone0		
GroupA	Mute			ToneA		Tone3		Tone13		
GroupB	Mute			ToneB		Tone1		Tone1A		
GroupC	Mute			ToneC		Tone1		Tone13		
GroupD	Mute			ToneD		ToneE		Tone13		
GroupE	Mute			ToneE		Tone1		Tone13		
GroupF	Mute	2) S1 = 8		ToneF	2) S1 = 9	Tone1	2) S1 = A	Tone13		2) S1 = B
Group10	Mute			Tone10		Tone12		Tone13		Jumper in position US of jumper field X1
Group11	Mute			Tone11		Tone3		Tone13		
Group12	Mute			Tone12		Tone1		Tone13		
Group13	Mute			Tone13		Tone2		Tone1A		
Group14	Mute			Tone14		Tone1		Tone13		
Group15	Mute			Tone15		Tone1		Tone13		
Group16	Mute			Tone16		Tone4		Tone13		
Group17	Mute			Tone17		Tone1C		Tone13		
Group18	Mute			Tone18		Tone1C		Tone13		
Group19	Mute			Tone19		Tone1		Tone0		
Group1A	Mute			Tone1A		Tone19		Tone13		
Group1B	Mute			Tone1B		Tone1		Tone13		
Group1C	Mute			Tone1C		Tone5		Tone13		
Group1D	Mute			Tone1D		Tone1F		Tone13		
Group1E	Mute			Tone1E		Tone9		Tone0		
Group1F	Mute			Tone1F		Tone19		Tone0		

1) Corresponding connections for input terminals 3, 4 and 5.

2) The signalling tone group GroupF ships in the following state. The assignment of the signalling tones may be changed by programming. The entry S1 = x identifies the required position of the rotary switch S1 (see „ Signalling tone group GroupF programming procedure “).

Table: Signalling tone description

	Parameter	Type	Standard	Sy nc	Timing diagram	
Tone0	1000Hz	Continuous	PFEER Toxic Gas			Jumper in position LS of jumper field X1
Tone1	800/1000Hz@ 0.25s	Alternating				
Tone2	500/1200Hz@ 0.3Hz 0.5s	Slow Whoop		✓		
Tone3	800/1000Hz@ 1Hz	Sweeping		✓		
Tone4	2400/2900@ 7Hz	Sweeping				
Tone5	2400/2900@ 1Hz	Sweeping		✓		
Tone6	500/1200Hz@ 0.3Hz	Sweeping		✓		
Tone7	1200/500Hz@ 1Hz	Sweeping	DIN / PFEER P.T.A.P.	✓		
Tone8	2400/2900@ 2Hz	Alternating		✓		
Tone9	1000Hz@ 1Hz	Intermittent		✓		
ToneA	800/1000Hz@ 0.875Hz	Alternating		✓		
ToneB	544Hz(100ms)/440Hz(400 ms)	Alternating	NF S-32-001	✓		
ToneC	1400Hz(1s)/1600Hz(0.5s)	Sweeping	NFC48-265	✓		
ToneD	660Hz@ 3.33Hz	Intermittent				
ToneE	660Hz/(1.8s), 1.8s off	Intermittent		✓		
ToneF	660Hz	Continuous				
Tone10	2400Hz@ 1Hz	Intermittent		✓		Jumper in position US of jumper field X1
Tone11	800Hz(0.25s), 1s off	Intermittent		✓		
Tone12	800Hz	Continuous				
Tone13	2400Hz	Continuous				
Tone14	554/440Hz@ 1Hz	Alternating		✓		
Tone15	544Hz@ 0.875Hz	Intermittent		✓		
Tone16	800Hz@ 2Hz	Intermittent		✓		
Tone17	800/1000Hz@ 50Hz	Sweeping				
Tone18	2400/2900Hz@ 50Hz	Sweeping				
Tone19	Mute					
Tone1A	554Hz	Continuous				
Tone1B	440Hz	Continuous				
Tone1C	800/1000Hz@ 7Hz	Sweeping				
Tone1D	420Hz 1.6Hz	Intermittent	Australian Alert	✓		
Tone1E	1200/500Hz@ 1Hz	Sweeping	DIN / PFEER P.T.A.P.	✓		
Tone1F	500/1200Hz@ 3.75s 0.25s	Slow Whoop	Australian Evac.	✓		

Possible applications

Single sounder with a fixed signalling tone:

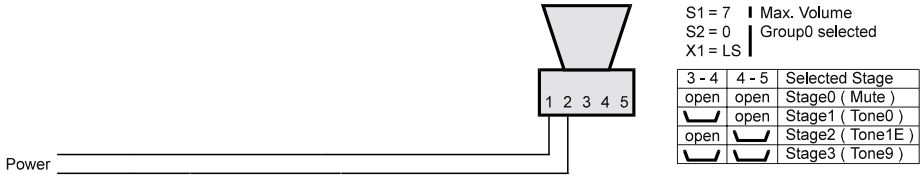

You have selected a signalling tone group according to the procedure described earlier in this manual. To select a fixed signalling tone (Stage 0, Stage 1, Stage 2 or Stage 3) from the signalling tone group, the control inputs must be connected accordingly. The control inputs are the terminals 3, 4 and 5, located in the sounder's electrical enclosure. Place the sounder with the horn opening resting on a level surface, loosen the 6 screws of the electrical enclosure lid and remove the lid.

Perform the setting of a fixed signalling tone as follows:

- Stage 0 No connections
- Stage 1 Connect terminal 3 and terminal 4 using a jumper
- Stage 2 Connect terminal 4 and terminal 5 using a jumper
- Stage 3 Connect terminals 3, 4 and 5 using a jumper.

Single sounder with variable signalling tone:

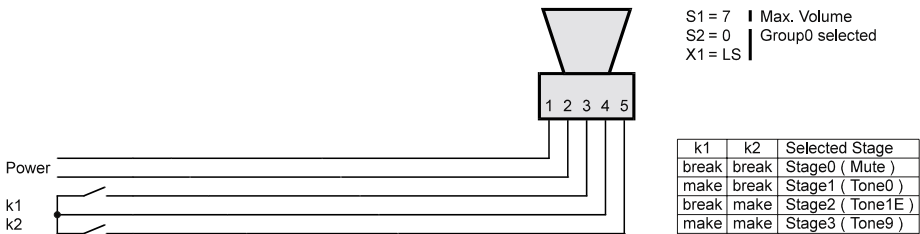

If there is a requirement for the ability to select the individual signalling tones of a signalling tone group (Stage 0, Stage 1, Stage 2 or Stage 3) during operation, terminals 3, 4 and 5 must be connected accordingly to the floating contacts of a control device. This may be prepared at this stage, or after the sounder has been mounted.

Select a signalling tone via floating contacts k1 and k2 as follows:

- Stage 0 Both contacts open
- Stage 1 Contact k1 closed, contact k2 open
- Stage 2 Contact k1 open, contact k2 closed
- Stage 3 Both contacts closed

Multi-sounder with a fixed signalling tone:

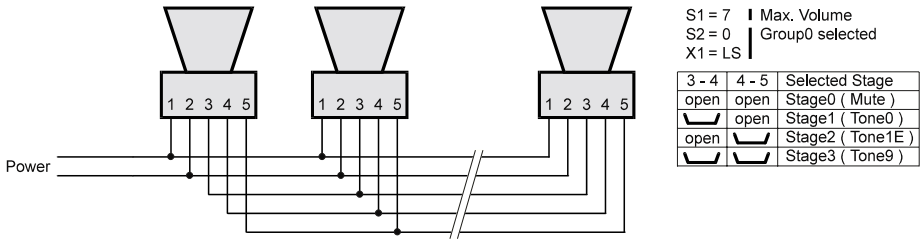

If several sounders are being operated simultaneously with the same signalling tone, it may be a good idea to synchronise the signalling tones, i.e. to make sure the signalling tones of all the sounders sound for an equally long period of time. This is only possible with the signalling tones for which “Sync” has been ticked off in the table “Signalling tone description”. To enable synchronisation, the terminals 3 of all the sounders, the terminals 4 of all the sounders and the terminals 5 of all the sounders must be interconnected. To select a fixed signalling tone (Stage 0, Stage 1, Stage 2 or Stage 3) from the set signalling tone group, the control inputs of one of the sounders must be connected accordingly. This may be prepared at this stage, or after the sounder has been mounted.

Perform the setting of a fixed signalling tone as follows:

- Stage 0 No connections
- Stage 1 Connect terminal 3 and terminal 4 using a jumper
- Stage 2 Connect terminal 4 and terminal 5 using a jumper
- Stage 3 Not a useful setting in this application, as synchronisation is not possible when terminals 3, 4 and 5 are interconnected.

Multi-sounder with variable signalling tone:

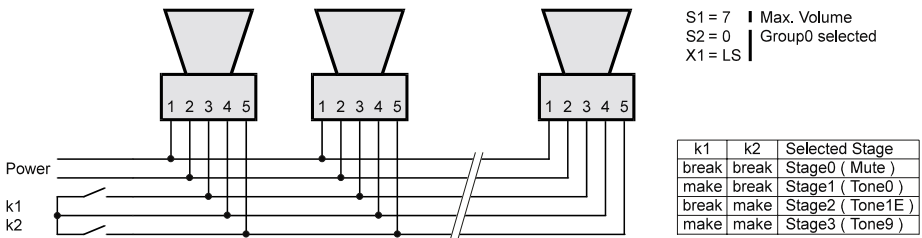

As „Multi-sounder with a fixed signalling tone“, except that the signalling tone may be chosen via floating contacts of a control device.

Select a signalling tone via floating contacts k1 and k2 as follows:







- Stage 0 Both contacts open
- Stage 1 Contact k1 closed, contact k2 open
- Stage 2 Contact k1 open, contact k2 closed
- Stage 3 Both contacts closed. Please note that for this selection a synchronisation of the signalling tones is not possible.

Mounting

The sounder is suited for wall and ceiling mounting. For mounting dimensions, see the dimension illustration (on page 12). The wall bracket included in the box is fastened with 2 screws (\varnothing 6 or 8 mm). To connect, loosen the 6 lid screws and remove the lid. The fasteners and the mounting surface must be able to safely carry the weight of the sounder.

Installation

Prior to leading the connecting sounder cables through the cable gland, 100 – 130 mm of the isolation must be removed. Before connecting the single connectors to the terminals, remove 8 to 10 mm of isolation from the connectors.

Terminal	Version 85 - 265VAC	Version 21.6 - 75VDC
1, 1	N	L+ / L-
2, 2	L1	L- / L+
3		
4		
5		

After connecting the loudspeaker, place the single conductors of the connecting cables flatly across the connecting terminals, in the direction of the cable gland.

Warning! To avoid the connectors getting pinched, do not place them over the sealing edge.

Use sufficiently long cables to facilitate positioning of the sounders at a later stage.

Close the lid

Prior to closing the lid, the sealing surfaces and the sealing must be checked for damage and dirt, and cleaned if necessary. Damaged seals must be replaced by original seals from the manufacturer.

Put the lid on. Make sure the lid sits straight, and that the „lid fastener“ has not been placed across the threaded lid bolt or across the sealing edge. Then turn the lid screw as far as it goes, and tighten lightly.

Positioning the sounder

Swing the sounder in the desired position and tighten both side screws on the wall bracket.

Operating position

In order to avoid a reduction of the volume due to dust, rainwater or other foreign matter, the horn should be mounted horizontally or facing downwards.

Care and maintenance

The sounder is maintenance-free. In very dusty or dirty surroundings, the sounder should nevertheless be cleaned with a damp cloth from time to time. Never use sharp objects for cleaning.

Special operating conditions

In order to maintain the given listening quality, the sounder must not be mounted in close vicinity of sources of magnetic fields with technically relevant frequencies.

Disposal

The device may be recycled as electronic waste. When the device is disassembled, plastics, metals and electronics are to be disposed of separately. In every single case the national requirements and regulations for waste disposal must be observed.

User Information

This is a flameproof device designed for operation in explosive atmospheres. As a group II, category 2 device it is designed for use in Zone 1 and 2.

Please note the following warnings and security information:

- 1.** The installation and adjustment of the device must be carried out by qualified personnel in accordance with the prescribed installation regulations taking the specified explosion category into account. Repairs only may be carried out by the manufacturer or by a person appointed by the manufacturer followed by a renewed product conformity inspection.
- 2.** This device corresponds to insulation class II according to EN 60335-1
- 3.** If the device is damaged, it may not be operated.
- 4.** While operating the device in business or industry facilities, the legally or otherwise required precautions against accidents resulting from the use of electrical systems and devices must be taken.
- 5.** The equipment may only be operated under the prescribed ambient conditions. Unfavourable ambient conditions not covered by the explosion category of the device can lead to damage of the device and thus present a potential danger to the user's life.
- 6.** During operation of the device the temperature must not exceed nor fall below the prescribed range of ambient temperatures. It is not allowed to operate the device with an additional cover. Avoid heat accumulation on the site!
- 7.** Please pay attention to the required operating position of the device.
- 8.** Only blind plugs and cable glands as prescribed by the manufacturer may be used.
- 9.** The sounder must be dead (no-voltage) before opening. Wait at least 15 minutes after switching off the power before opening the device!
- 10.** The device may only be cleaned using a damp cloth in order to avoid electrostatic charging. Should these points not be observed, the explosion protection of the device cannot be guaranteed. The device is then a potential source of danger to life of the user and can cause the ignition of an explosive atmosphere.

Dimensions

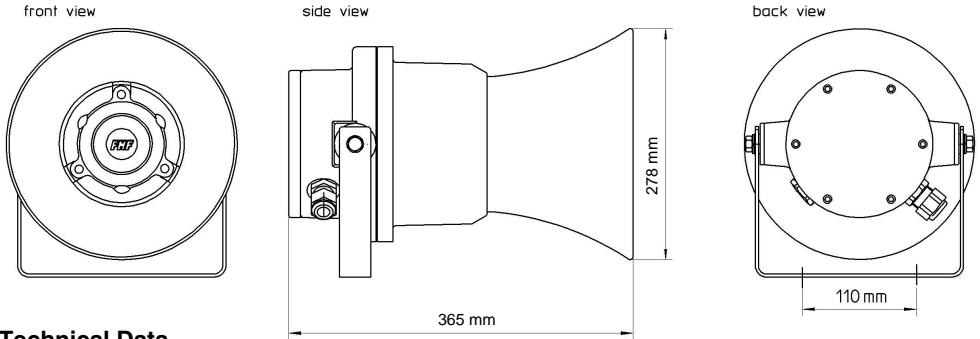

Technical Data

Type:

dHE

Testing and certification:

Explosion category:	CE0408  II 2 G EEx dem IIC T6
EC type examination certificate	PTB 03 ATEX 1232
Housing degree of protection:	IP 66 IEC 60529
Insulation class	II
Time to wait before opening the device after turning off operating power	≥ 15 minutes

Housing:

Housing material	Plastic
Metal components	Stainless steel V4A (ASTM 316)
Dimensions	~ Ø 278 x 365 mm
Weight	~ 5.9kg

Electrical connections:

	AC-version	DC-version
Mains connection (terminals 1 - 2)	L1, N	L+, L-
- Operating voltage U_B	85 – 265VAC	21.6 - 75VDC
- Operating frequency	50 – 60Hz	---
- Power consumption P (Tone1B, Max. sound pressure)	≤12.5W ¹⁾	≤2.5W ¹⁾
- Power consumption (mute)	≤2,5W	≤ 2.5W
- Power factor $\cos(\varphi)$	0.5 – 0,7 ²⁾	---
Control inputs (terminals 3 - 4 / 4 - 5)	all versions	
- Open circuit voltage U_O	≤ 5.5V	
- Short circuit current I_O	≤ 0.6mA	
- Number of sounders connected in parallel	≤ 32	
- Wiring length	≤ 3000m Minimum cross-section 0.75 mm ²	

¹⁾ Power consumption is, to a great extent, independent of the operating voltage. It does, however, depend on the signalling tone and the sound pressure level. The given value specifies the highest power consumption of the device.

²⁾ The power factor of the alternating current version depends on the operating voltage. The following formula determines the operating voltage dependent operating current I_B of the device.

$$I_B \approx \frac{P}{U_B * (0,794 - 1,11 * 10^{-3} * U_B)}$$

For the DC version the following is valid: $I_B = P / U_B$

Connecting terminals:

Clamping capacity, single wired,
fine-wired or multi-wired
Multiconductor connection

≤ 2.5mm² (AWG 14)
maximum 2 x 1mm² ³⁾

³⁾ Multiconductor connection is allowed at same cross-section and same conductor type, up to the given value. In case of multi-wired conductors, wire-end sleeves are required. Pay attention to EN 50019!

Acoustic data:

Signal tones
Sound pressure
Angle, -6 dB at 1000 Hz

31 tones
≤ 119 dB(A) at 1 m distance
≤ 130°

Operating conditions:

Mounting site
Operating mode
Operating position

Indoors and outdoors
100% continuous operation
any, although preferably such that the horn is protected from intrusion of dust, rain water and other pollution.

Ambient temperatures:

Operating
Transport
Storage

-20°C to +40°C
-25°C to +70°C
-25°C to +70°C

Änderungen vorbehalten
Subject to change without notice
Sous réserve de modifications
Sujeto a modificaciones

J. Auer Fabrik Elektrischer Maschinen Gesellschaft m. b. H.

Perfektastr. 102
A-1230 Wien

Telefon (00431) 813 82 20 <http://www.auer-signal.com>
Telefax (00431) 815 99 51 e-mail: office@auer-signal.com

Ä

